

CHERNG HORNG

橡 膠 版 印 刷 機



**FLEXOGRAPHIC
PRINTING
MACHINE**

成 虹 機 械 股 份 有 限 公 司
CHERNG HORNG MACHINERY CO., LTD

橡膠版印刷機特點：

1. 本機適合印刷捲筒紙、包裝紙、PP、PE 塑膠袋、玻璃紙。
2. 佔地極小，少量人員即可操作，節省人力。
3. 油壓升降版面，操作簡單、準確性高、停、開車均無不良品產生。
4. 配有數目控制，達到預定數目，自動停電。
5. 油壓起落版，停車後油墨自動攪拌。
6. 熱風乾燥與冷風乾燥設備相配合高速生產，停車時，冷熱電氣立即自動斷電達到理想與安全。
7. 配有自動停機。

CHARACTERISTICS OF CHERNG HORNG FLEXOGRAPHIC PRINTING MACHINE:

1. This Machine is suitable to printing of rolling paper, Packing paper, glass paper, P.P., P.E. and Polyesterene bags.
2. Robust construction minimizes space occupied and enhances productivity.
3. Using hydraulic system to set the printing plates, it is easy and accurate. There will be no defects when starting and stopping the machine.
4. The built-in impression counter can be presented and stops the machine automatically when the desired quality of prints is acquired, and starts again on reset.
5. The throw-off or on action of printing cylinder is hydraulically operated. The interlocking mechanism keeps the inking rolls running to avoid drying of ink on such rolls, accomplishing the throw-off of printing cylinder.
6. Using a hot-air dryer and a cold-air fan simultaneously, it makes the production more speedy. The dryer and fan will shut down automatically when the machine stops, it makes this machine more safe.
7. The built-in stops the machine automatically.

備註：隨機只付一套印刷輪(尺寸介於7½"~15"之間)，其餘須另購

Remark: One complete set of printing roll in any size between 7½"-15" is supplied free of charge, extra roll as option.

01. BLOWER 風箱
02. HEATER 電熱
03. COUPLER 聯結器
04. TENSION ROLLER 壓袋輪
05. MAIN ROLLER 機台輪
06. HORIZONTAL REGISTER 左右調整
07. STEEL ROLLER 網輪
08. PRINTING UNIT ADVANCE 印刷單位鎖
09. RUBBER ROLLER 膠輪
10. INKING UNIT ADVANCE 油墨調整
11. INK TRAY 油墨槽
12. INKING & PRINTING UNIT ADVANCE 油墨及印刷調整
13. PRINTING UNIT ADVANCE 印刷調整
14. HYDRAULIC TUBE 油壓管
15. DC MOTOR 主機馬達
16. POWER SOURCE 電源
17. AIR TUBE 熱風管
18. HANDWHEEL 手輪
19. VERTICAL REGISTER LOCK 上下調整
20. MAIN SWITCH 總開關
21. DIGITAL DISPLAY 數字指示
22. LUBRICATION UNIT 注油器
23. COUPLING 聯結軸
24. TAKE OFF ROLLER 傳動輪
25. CONTROL BOX 控制箱 (DC馬達)
26. RELWIND UNIT 捲取座
27. FINISHED PRINT FILM 放袋座

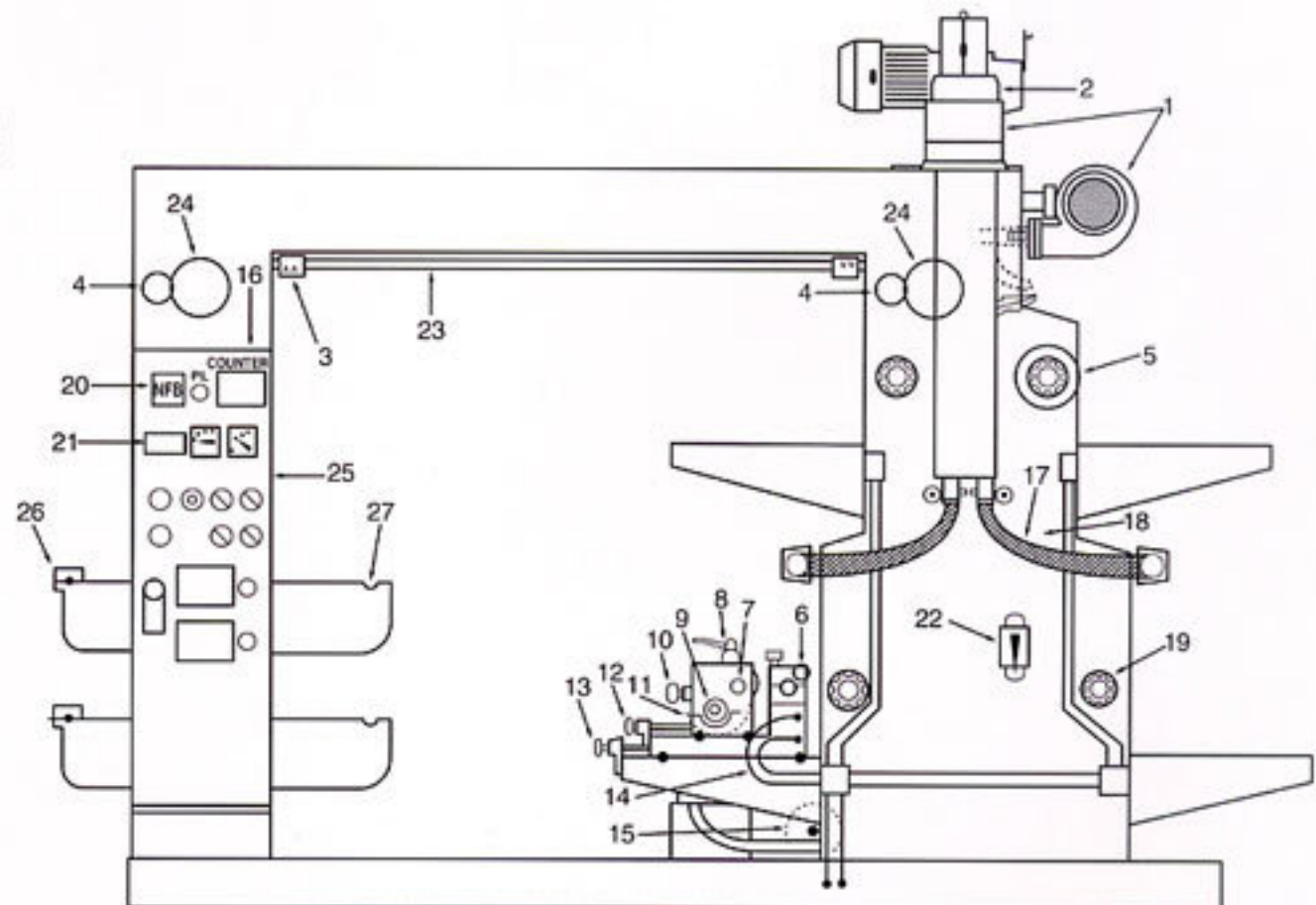

CH-2004

二色橡膠版吹袋機連線印刷機

2 COLORS FLEXOGRAPHIC IN-LINE PRINTING MACHINE

印刷寬度 Printing width (mm)	500	800	1000
說明 Description			
印刷顏色 Color printed	2		
印刷速度(最快) Printing speed (max.) (M/min.)	90		
袋子通過寬度(最寬) Film passing width (max.) (mm)	600	900	1100
印刷長度 Printing length (mm)	200-1000		
印刷組合 Printing possibility	0+2, 1+1		
主馬達 Main motor (HP)	5	7 1/2	10
電熱 Heater (KW)	1.5KW×6支		1.5KW×10支
電熱送風機 Blower for heater (HP)	1/2 HP×1, 5HP×1		
油壓馬達 Hydraulic pump motor (HP)	1HP		
總電力 Total Power (KW)	10	11	12

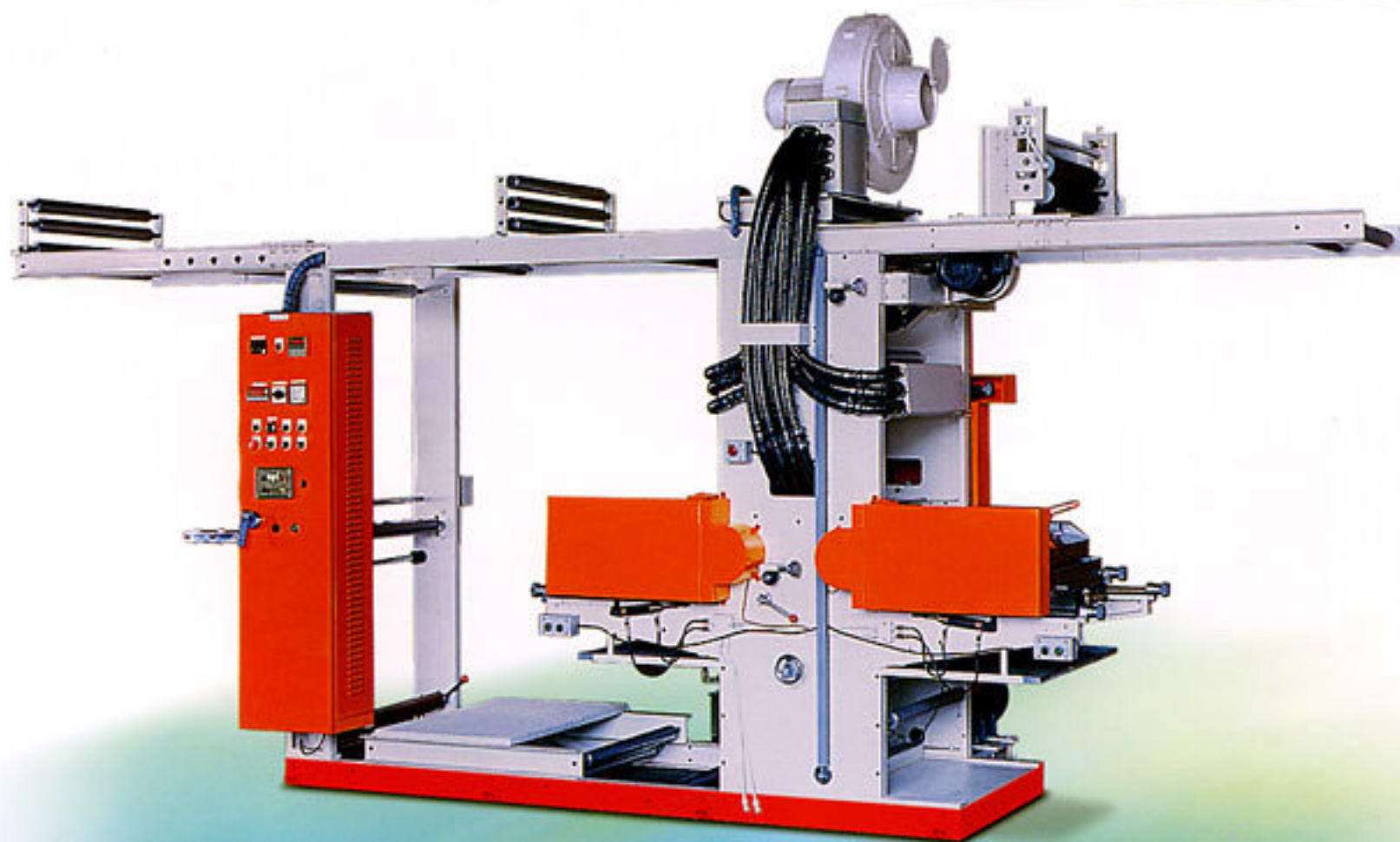

印刷寬度 Printing width (mm)	機器長 Length (cm)	機器寬 Width (cm)	機器高 Height (cm)	機器重 Net weight (kg)	機器+木箱重 Gross weight (kg)	付船載位 Loading Volume (cm)
500	550	180	265	2200	2500	215×195×220
800	550	220	265	3000	3300	215×225×220
1000	550	260	265	3800	4100	215×255×220

備註：1. 任何印刷尺碼均可訂製 Any size is available as per ordered

機械規格局部修改不另行通知貴戶 Specification is subject to change without notification of modification.

2. 顏色不在此限。Except colors.

3. 隨機只付一套印刷輪(尺寸介於15)，其餘須另。One complete set of printing roll in any size between 7 1/2"-15" is supplied free of charge, extra rolls as option.

CH-4004

四色橡膠版吹袋機連線印刷機

4 COLORS FLEXOGRAPHIC IN-LINE PRINTING MACHINE

說明 Description	印刷寬度 Printing width (mm)		
	500	800	1000
印刷顏色 Color printed	4		
印刷速度 (最快) Printing speed (max.) (M/min.)	90		
袋子通過寬度 (最寬) Film passing width (max.) (mm)	600	900	1100
印刷長度 Printing length (mm)	200-1000		
印刷組合 Printing possibility	0+4, 1+3, 2+2		
主馬達 Main motor (HP)	7 1/2		10
電熱 Heater (KW)	1.5KW×13支		1.5KW×16支
電熱送風機 Blower for heater (HP)	1/2 HP×1, 5HP×1		
油壓馬達 Hydraulic pump motor (HP)	1HP		
總電力 Total Power (KW)	25	30	35

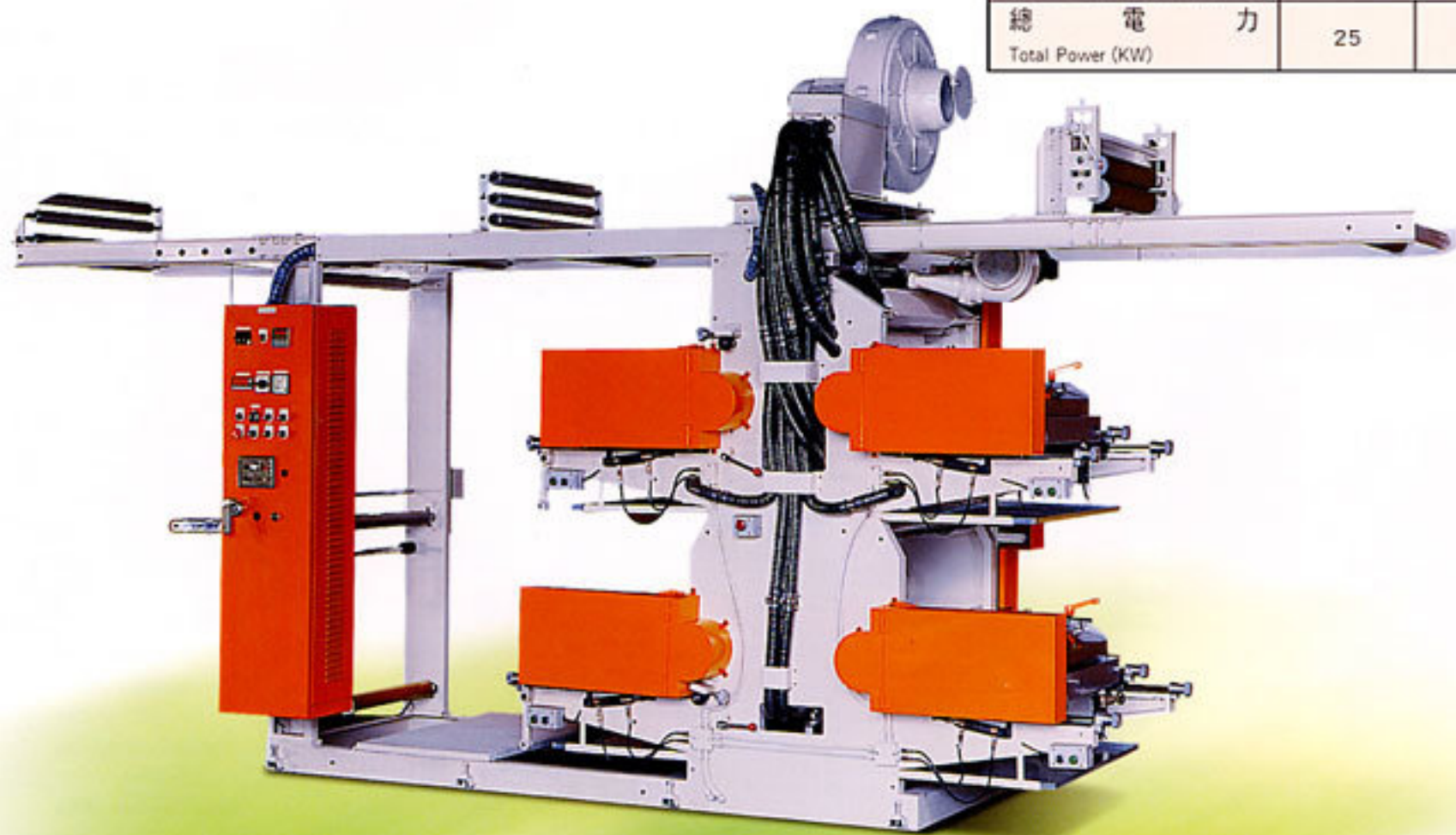

印刷寬度 Printing width (mm)	機器長 Length (cm)	機器寬 Width (cm)	機器高 Height (cm)	機器重 Net weight (kg)	機器+木箱重 Gross weight (kg)	付船載位 Loading Volume (cm)
500	550	180	265	2500	2800	215×195×220
800	550	220	265	3300	3600	215×225×220
1000	550	260	265	4100	4400	215×255×220

備註：1. 任何印刷尺碼均可訂製 Any size is available as per ordered

機械規格局部修改不另行通知貴戶 Specification is subject to change without notification of modification.

2. 顏色不在此限。Except colors.

3. 隨機只付一套印刷輪 (尺寸介於15) · 其餘須另。One complete set of printing roll in any size between 7 1/2"-15" is supplied free of charge, extra rolls as option.

CH-2001

二色橡膠版印刷機

2 COLOR FLEXOGRAPHIC PRINTING MACHINE



印刷寬度 Printing width (mm)	500	800	1000
說明 Description			
印刷顏色 Color printed	2		
印刷速度(最快) Printing speed (max.) (M/min.)	60		
袋子通過寬度(最寬) Film passing width (max.) (mm)	600	900	1100
印刷長度 Printing length (mm)	200-1000		
印刷組合 Printing possibility	0+2, 1+1		
主馬達 Main motor (HP)	2	3	3
電熱 Heater (KW)	1.5KW×7支	1.5KW×10支	1.5KW×13支
電熱送風機 Blower for heater (HP)	1/2 HP 2 HP	1/2 HP, 5HP	
油壓馬達 Hydraulic pump motor (HP)	1HP		
網板輪馬達 Hydraulic pump motor (HP)	1/2		
拉袋輪馬達轉矩 (Kg)	30X1	30X1	50X1
總電力 Total Power (KW)	13	16	18

印刷寬度 Printing width (mm)	機器長 Length (cm)	機器寬 Width (cm)	機器高 Height (cm)	機器重 Net weight (kg)	機器+木箱重 Gross weight (kg)	付船載位 Loading Volume (cm)
500	250	189	260	2000	2700	258×180×220
800	250	215	285	2300	3000	258×200×220
1000	250	235	285	2500	3200	258×210×220

CH-4001

四色橡膠版印刷機 4 COLOR FLEXOGRAPHIC PRINTING MACHINE

印刷寬度 Printing width (mm)	500	800	1000
說明 Description			
印刷顏色 Color printed	4		
印刷速度 (最快) Printing speed (max.) (M/min.)	60		
袋子通過寬度 (最寬) Film passing width (max.) (mm)	600	900	1100
印刷長度 Printing length (mm)	200-1000		
印刷組合 Printing possibility	0+4, 1+3, 2+2		
主馬達 Main motor (HP)	3	5	7 1/2
電熱 Heater (KW)	1.5KW×13支	1.5KW×16支	1.5KW×19支
電熱送風機 Blower for heater (HP)	1/2 HP×1, 5HP×1		1/2 HP×1, 7 1/2HP×1
油壓馬達 Hydraulic pump motor (HP)	1HP		
網板輪馬達 Hydraulic pump motor (HP)	1/2		
復捲馬達轉矩 (Kg)	30X2	30X2	50X2
總電力 Total Power (KW)	20	23	25

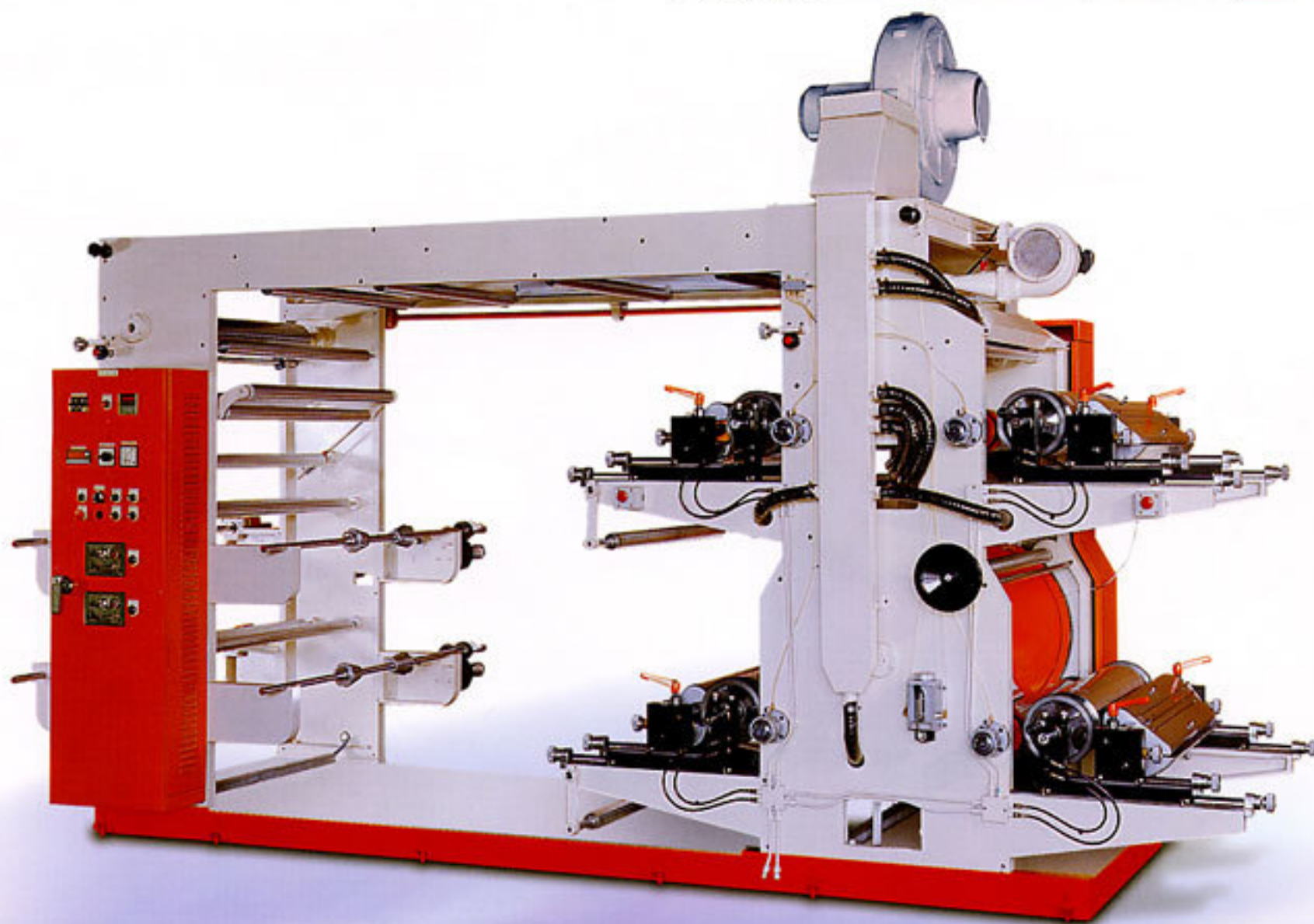

印刷寬度 Printing width (mm)	機器長 Length (cm)	機器寬 Width (cm)	機器高 Height (cm)	機器重 Net weight (kg)	機器+木箱重 Gross weight (kg)	付船載位 Loading Volume (cm)
500	440	189	285	3800	4800	457×210×230
800	440	215	285	4300	5300	457×210×230
1000	440	235	285	4800	5800	457×210×230

CH-HS4001 HI-SPEED

四色橡膠版高速印刷機

4 COLOR FLEXOGRAPHIC HIGH SPEED PRINTING MACHINE

印刷寬度 Printing width (mm)	500	800	1000
說明 Description			
印刷顏色 Color printed	4		
印刷速度(最快) Printing speed (max.) (M/min.)	85		
對講機 EPC	1		
袋子通過寬度(最寬) Film passing width (max.) (mm)	600	900	1100
印刷長度 Printing length (mm)	200-1000		
印刷組合 Printing possibility	0+4, 1+3, 2+2		
主馬達 Main motor (HP)	5	7 1/2	7 1/2
電熱 Heater (KW)	1.5KW×16支	1.5KW×19支	1.5KW×22支
電熱送風機 Blower for heater (HP)	1/2 HP×1, 2HP×2, 5HP×1		1/2 HP×1, 7 1/2HP×1, 2HP×2
油壓馬達 Hydraulic pump motor (HP)	1HP		
網板輪馬達 Hydraulic pump motor (HP)	1/2		
復捲馬達轉矩 (Kg)	30X2	30X2	50X2
總電力 Total Power (KW)	22	25	28

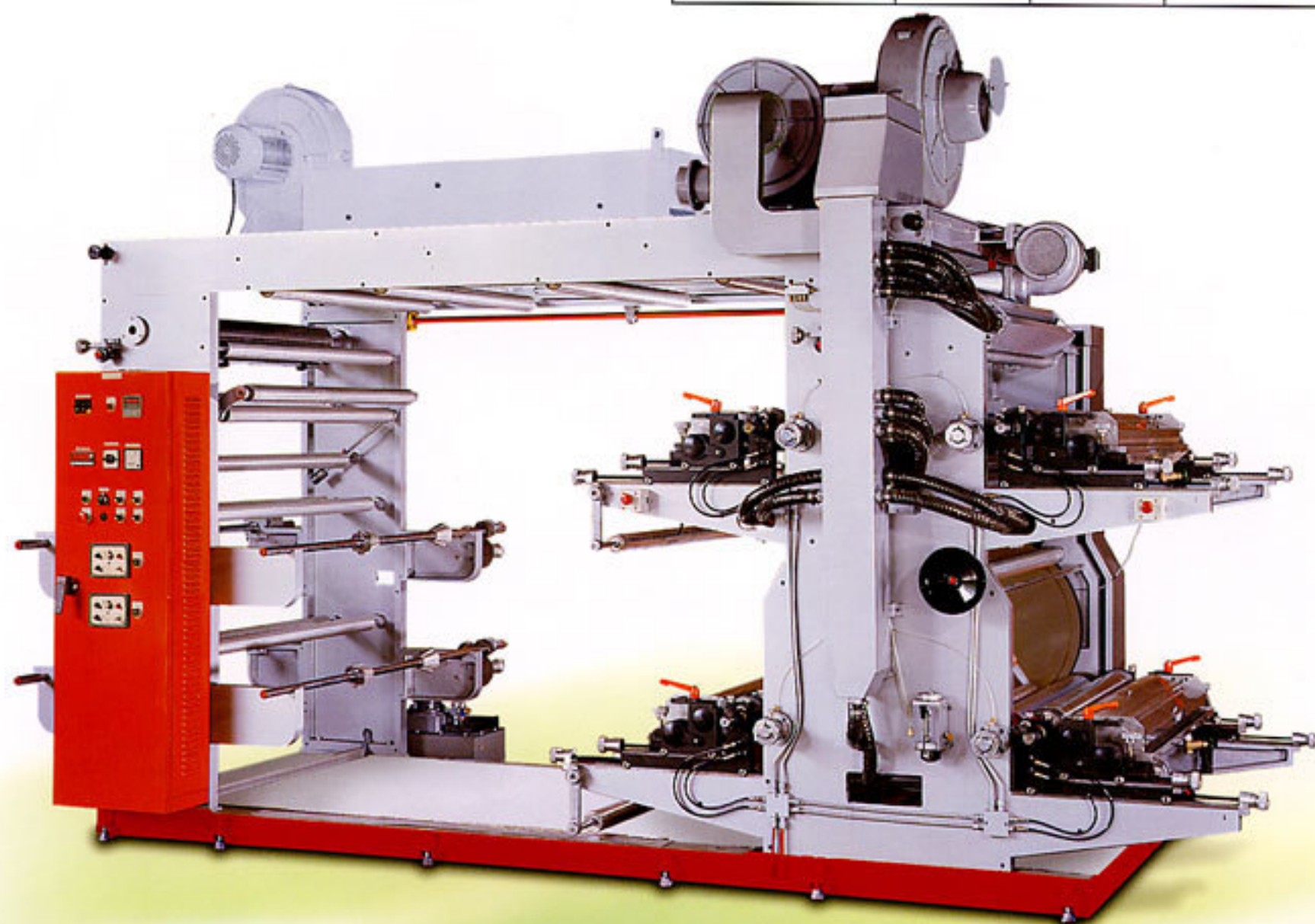

印刷寬度 Printing width (mm)	機器長 Length (cm)	機器寬 Width (cm)	機器高 Height (cm)	機器重 Net weight (kg)	機器+木箱重 Gross weight (kg)	付船載位 Loading Volume (cm)
500	440	189	285	4000	5200	457×210×230
800	440	215	285	4500	6000	457×210×230
1000	440	235	285	5000	6500	457×210×230

CH-6001

六色橡膠版印刷機

6 COLOR FLEXOGRAPHIC PRINTING MACHINE

印刷寬度 Printing width (mm)	500	800	1000
說明 Description			
印刷顏色 Color printed	6		
印刷速度 (最快) Printing speed (max.) (M/min.)	60		
袋子通過寬度 (最寬) Film passing width (max.) (mm)	600	900	1100
印刷長度 Printing length (mm)	200-800		
印刷組合 Printing possibility	0+6, 1+5, 2+4, 3+3		
主馬達 Main motor (HP)	5	7 1/2	7 1/2
電熱 Heater (KW)	1.5KW×13支	1.5KW×16支	1.5KW×19支
電熱送風機 Blower for heater (HP)	1/2 HP×1, 5HP×1		1/2 HP×1, 7 1/2HP×1
油壓馬達 Hydraulic pump motor (HP)	1HP		
網板輪馬達 Hydraulic pump motor (HP)	1/2		
復捲馬達轉矩 (Kg)	30X2	30X2	50X2
總電力 Total Power (KW)	22	25	28

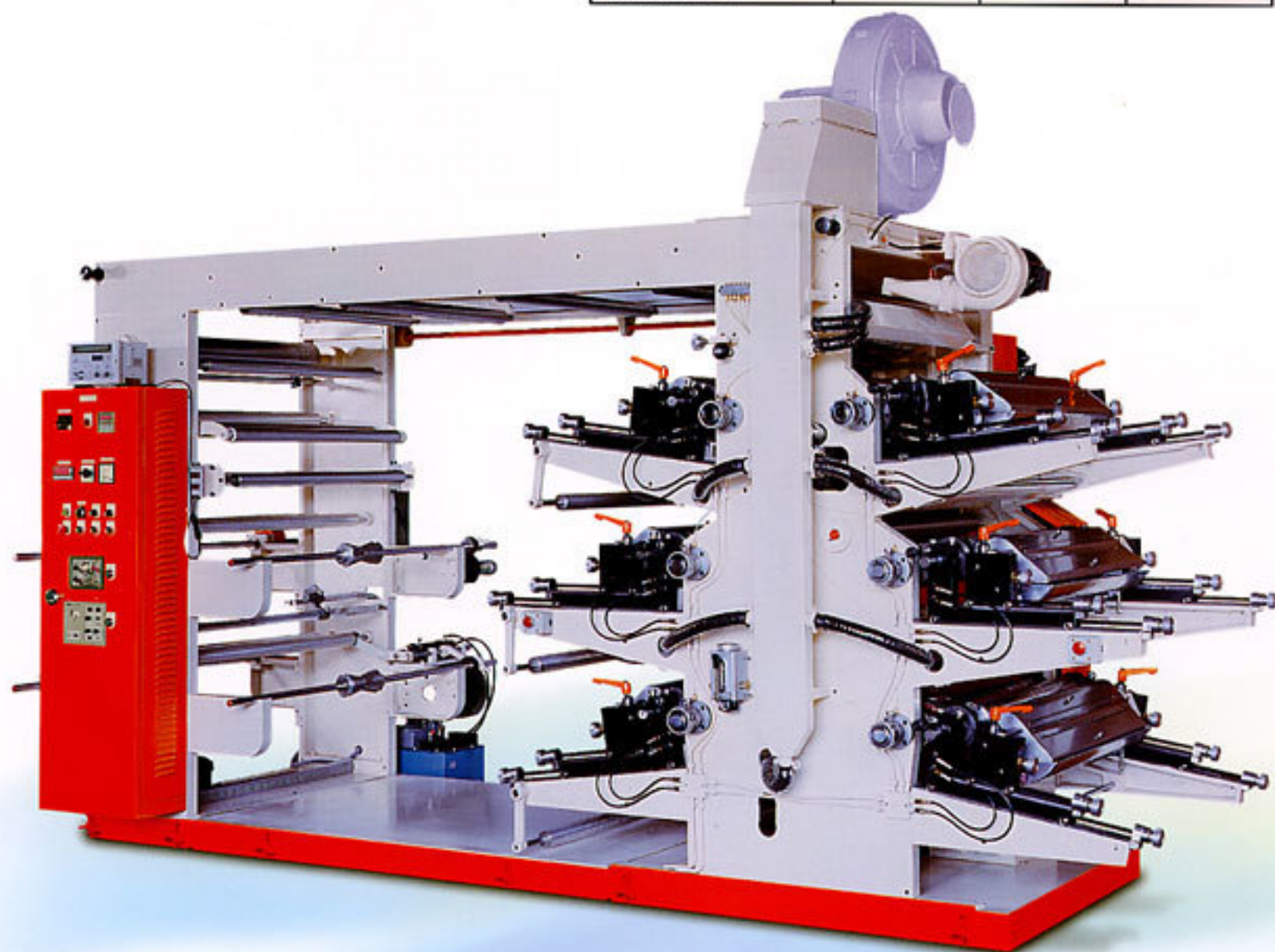

印刷寬度 Printing width (mm)	機器長 Length (cm)	機器寬 Width (cm)	機器高 Height (cm)	機器重 Net weight (kg)	機器+木箱重 Gross weight (kg)	付船載位 Loading Volume (cm)
500	440	189	285	4000	4800	457×210×230
800	440	215	285	4500	5300	457×210×230
1000	440	235	285	5000	5800	457×210×230

CH-HS6001 HI-SPEED

六色橡膠版高速印刷機

6 COLOR FLEXOGRAPHIC HIGH SPEED PRINTING MACHINE

印刷寬度 Printing width (mm)	500	800	1000
說明 Description			
印刷顏色 Color printed	6		
印刷速度(最快) Printing speed (max.) (M/min.)	85		
對講機 EPC	1		
袋子通過寬度(最寬) Film passing width (max.) (mm)	600	900	1100
印刷長度 Printing length (mm)	200-800		
印刷組合 Printing possibility	0+6, 1+5, 2+4, 3+3		
主馬達 Main motor (HP)	5	7 1/2	7 1/2
電熱 Heater (KW)	1.5KW×16支	1.5KW×19支	1.5KW×22支
電熱送風機 Blower for heater (HP)	1/2 HP×1, 2HP×2, 5HP×1		1/2 HP×1, 7 1/2HP×1 2HP×2
油壓馬達 Hydraulic pump motor (HP)	1HP		
鋼板輪馬達 Hydraulic pump motor (HP)	1/2		
復捲馬達轉矩 (Kg)	30X2	30X2	50X2
總電力 Total Power (KW)	25	28	30

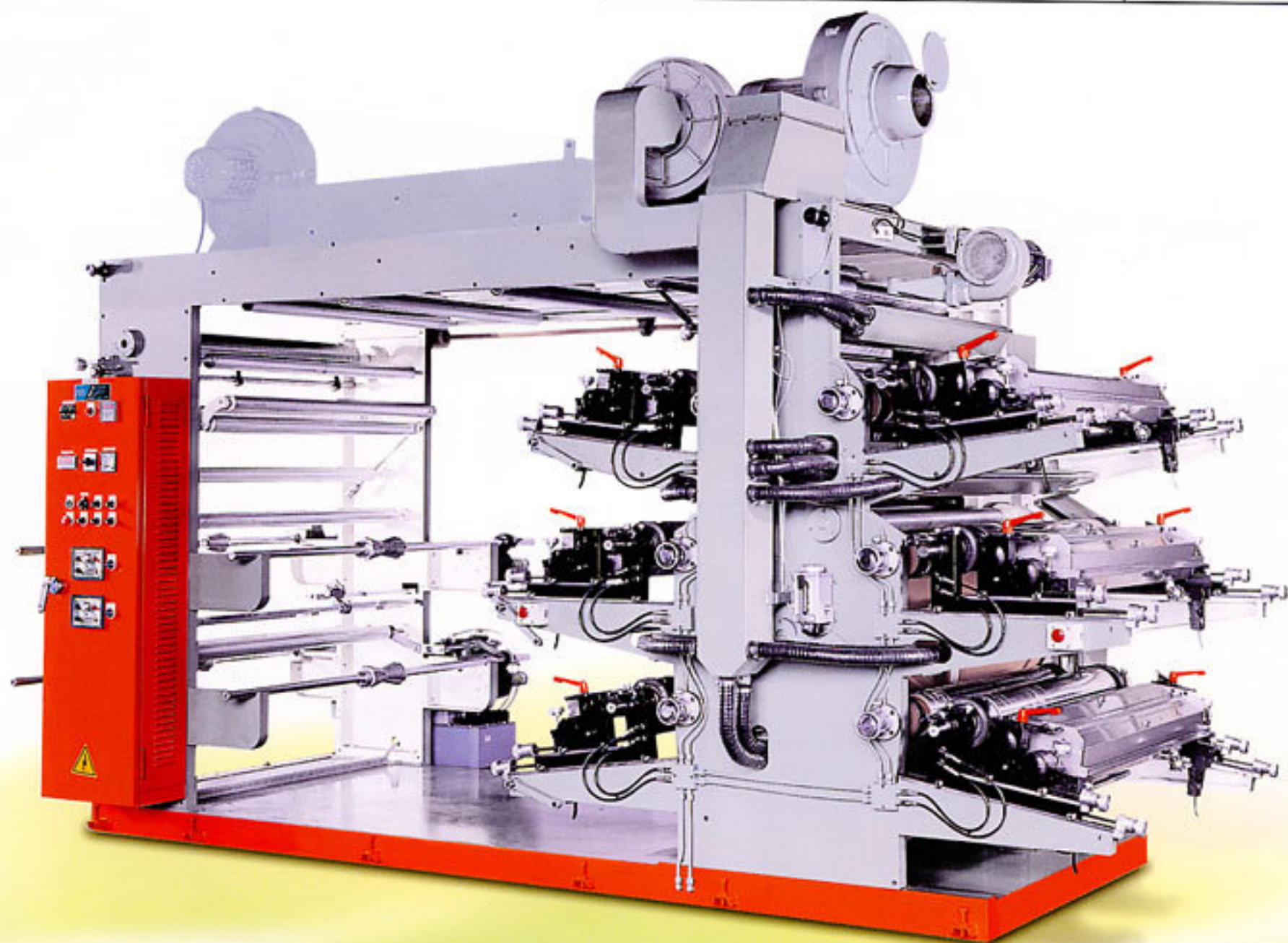

印刷寬度 Printing width (mm)	機器長 Length (cm)	機器寬 Width (cm)	機器高 Height (cm)	機器重 Net weight (kg)	機器+木箱重 Gross weight (kg)	付船載位 Loading Volume (cm)
500	440	189	285	4200	5200	457×210×230
800	440	215	285	4800	6000	457×210×230
1000	440	235	285	5300	6500	457×210×230

CH-HS 8001

八色橡膠版印刷機

8 COLOR FLEXOGRAPHIC PRINTING MACHINE

印刷寬度 Printing width (mm)	800	1000	1200
說明 Description			
印刷顏色 Color printed	8		
印刷速度 (最快) Printing speed (max.) (M/min.)	60		
對講機 EPC	1		
袋子通過寬度 (最寬) Film passing width (max.) (mm)	900	1100	1300
印刷長度 Printing length (mm)	200-1000		
印刷組合 Printing possibility	0+8, 1+7, 2+6, 3+5, 4+4		
主馬達 Main motor (HP)	7 1/2	10	10
電熱 Heater (KW)	1.5KW × 22支	1.5KW × 25支	1.5KW × 28支
電熱送風機 Blower for heater (HP)	1/2 × 1, 2 × 2, 5 × 1	1/2 × 1, 2 × 2, 7 1/2 × 1	
油壓馬達 Hydraulic pump motor (HP)	1HP		
網目輪馬達 ink roll motor (HP)	1HP		
拉袋轉矩馬達 Torque Motor (kg)	DC2HP × 2		
吊車 auto hanger	1/2HP × 2		
張力控制 Tension controller	2		
總電力 Total Power (KW)	40	43	43

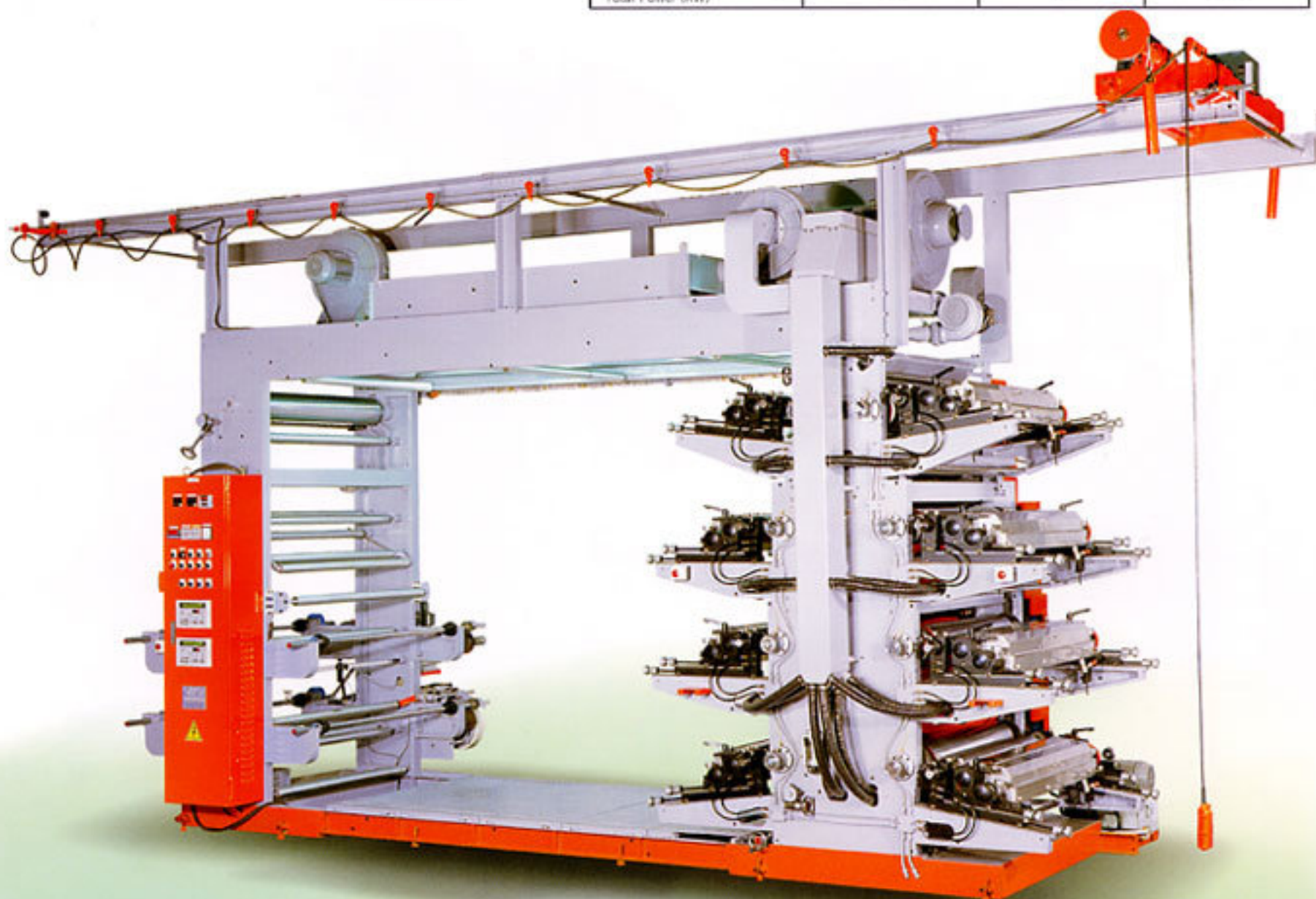

印刷寬度 Printing width (mm)	機器長 Length (cm)	機器寬 Width (cm)	機器高 Height (cm)	機器重 Net weight (kg)	機器+木箱重 Gross weight (kg)	付船載位 Loading Volume (cm)
800	730	220	400	6500	7800	820 × 210 × 230
1000	730	250	400	7000	8300	820 × 210 × 230
1200	730	260	400	7500	8800	820 × 210 × 230

備註：任何印刷尺碼均可訂製 Any size is available as per ordered.

機械規格局部修改不另行通知貴戶 Specification is subject to change without notification of modification.

1 COLOR FLEXO PRINTER (IN-LINE)

一色連線用印刷機

FEATURES:

1. FULL SIZE PRINTING
2. NO SPACE REQUIRED. DESIGNED TO BE ATTACKED WITH BLOW-FILM MACHINE.
3. EQUIPED WITH INK CIRCULATION PUMP & INK TANK FOR EASY INK-FILLING.
4. HIGH SPEED PRINTING AND FINE INK DRYING

1 COLOR PRINTER

- PRINTING WIDTH : ACCORDING TO BLOW-FILM MACHINE
- PRINTING LENGTH : 200MM-700MM



PLATE MAKING MACHINE 製版機

Exposing Machine

Strong absorption vacuum machine with noise-free effect, super-strong UV tube provide most steady wave.

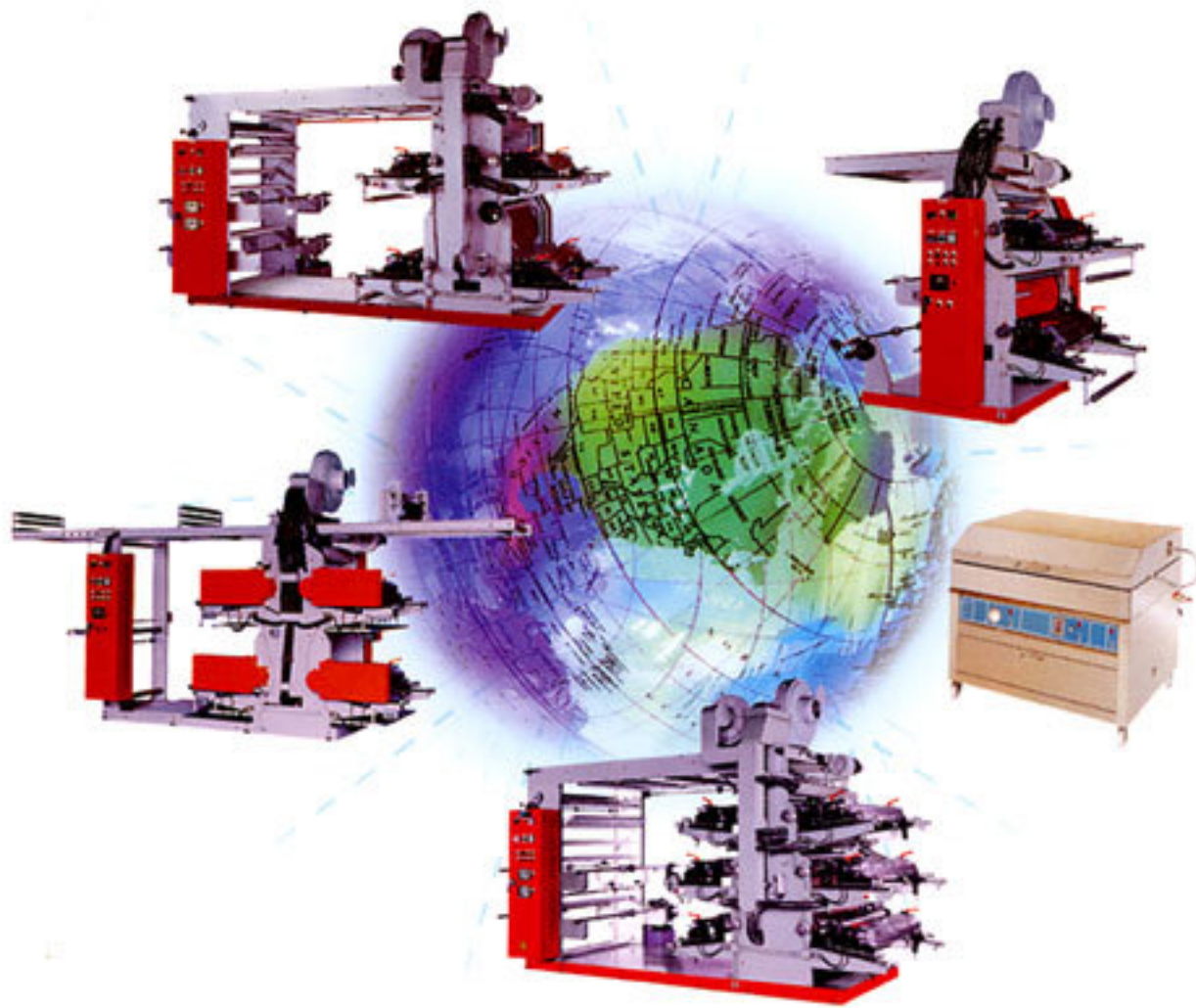

Plate-wash-out-Drying

Made by stainless steel, applicable to water, alcohol, and solvent. Plate-cleaning + Drying complete piece device. Space free and easy operation.



Description	Exposing Machine		Plate-cleaning + Drying	
	GT-PA2	GT-PB3	GT-PA2	GT-PB3
Max Area of Plate	62X44CM	52X37CM	62X44CM	52X37CM
Power Reduired	1.2kw	0.8kw	2.5kw	1.5kw
Machine Size (CM)	76X77X38	70X64X38	79X91X92	68X76X92
Machine Wt	52kw	45kw	110kw	75kw



成虹機械股份有限公司
CHERNG HORNG MACHINERY CO., LTD.

台灣台北縣三重市中正北路 393 巷 2 號
ADD: NO.2, LANE 393, ZHONGZHENG N. RD., SANCHONG
CITY, TAIPEI COUNTY 24157, TAIWAN

P.O.BOX:42-123 TAIPEI, TAIWAN,
TEL:886-2-29813178 · 29813187 · 29829753
FAX:886-2-29813455
<http://www.extruder.com.tw>
E-Mail:extruder@ms8.hinet.net